

Quads For Fun

<http://quadsforfun.wix.com/quadsforfun>

quadsforfun@outlook.com

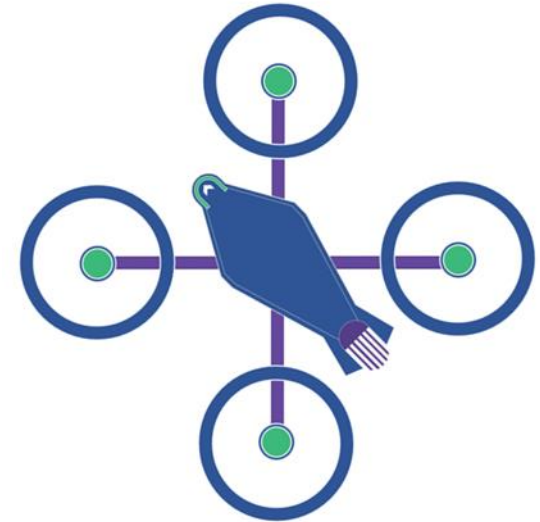



**THE BASIC UNDERSTANDING
ABOUT QUADCOPTERS**



THE BASIC UNDERSTANDING ABOUT QUADCOPTERS

The Quadcopter (Quad) is also called Quadrocopter, Quadricopter, Quad Rotor or Drone. They all belong to the multi rotors RC category. A Quad have four propellers arranged in across type configuration. The propellers are fixed pitch, two will spin clockwise and the other two will spin counter clockwise. By precisely spinning these four propellers at different speeds, the aircraft is able to take off vertically, hover and fly in all directions. The Quads are very simple when compared to RC helicopters. All that is needed is a frame, motors, the ESC's (Electronic Speed Controller), propellers, the receiver-transmitter, an electronic stabilization system and a Li-Po battery.

#	Quad Brands	Website
1	Align	http://www.align.com.tw/alignhtml/EN/index.php
2	Blade	http://www.bladeheli.com/
3	DJI	http://www.dji.com/
4	Dualsky	http://www.dualsky.com/
5	Heli-Max	http://www.helimax-rc.com/
6	Hubsan	http://www.hubsan.com/index.htm
7	Jian Jian Toys	http://www.jjrctoy.com/En/Index
8	Lotus RC	http://www.lotusrc.net/en/index.asp
9	Nine Eagles	http://www.nineeagle.com/
10	Parrot	http://www.parrot.com/usa/
11	3D Robotics	http://3drobotics.com/
12	RC Logger	http://www.rclogger.com/
13	Silverlit	http://www.silverlit.com/
14	Syma Toys	http://www.symatoys.com/
15	Traxxas	http://traxxas.com/products/models/heli/6208qr1
16	UDI Toys	http://www.udirc.com/eng/allp.asp
17	Vitality	http://www.vitality-toys.com/
18	Walkera	http://www.walkera.com/en/
19	WL Toys	http://www.wlmodel.com/English/



LENGTH x WIDTH x HEIGHT: these are the main dimensions of the Quad. Different brands provide measures of their products in different ways. Some use the full diameter. Other shows measurements of shaft to shaft combined with the size of propellers. Most of them use the three dimensions, length, width and height.

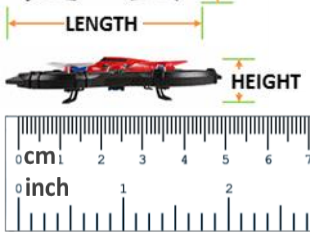

Measures of Length			
1 meter (m)	=	1000 millimeters (mm)	
1 meter (m)	=	100 centimeters (cm)	
1 inch (")	=	2.54 centimeters (cm)	
1 inch (")	=	25.4 millimeters (mm)	
Measures of Weight			
1 gram (g)	=	1000 milligrams (mg)	
1 kilogram (kg)	=	1000 grams (g)	

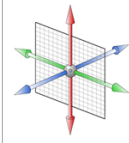

6-AXIS GYRO: it means 3D gyro (3 axis) + 3D accelerometer. In most of the cases, it's also 3D-compass. It's made for avoiding failure of the device and make the flight really more stable and easy to control.

A 3D flight system can only be around 3 axes (roll, yaw and pitch). The other 3 parameters may be from an accelerometer, that also gives the rotational data around those same 3 axes. A 6 axis gyro quad is more stable than a 3 axis gyro.



LITHIUM POLYMER BATTERY: there are huge variety of batteries available for Quads. The desirable combination of specs should be: low budget, correct size, less weight, longest flight times and correct voltage-amp (power).

CAPACITY (mAh) is the main number shown on battery label. It's measured in mAh (Milliamp/hour). Keeping simple terms, a 2100 mAh battery will run for twice as long as a 1000mAh battery. Batteries have different sizes, plugs, wire and charge rates.

DISCHARGE (C) is the amount of power the battery can push out. It's direct linked to the power level required of the motors. A higher "C" rated battery will last longer if run at a lower rate. Example - a 30C battery run at 20C maximum will have a longer cycle life than a 20C run at 20C each flight.

VOLTAGE (V): Li-Po cells have a nominal voltage of 3.7v per cell. Fully charged should be 4.2v and when discharged, never be below 3v. The Li-Po batteries are made up of layers of multiple cells. A 3S battery means it's 3 x 3.7v = 11.1v (means 3 cell pack).

WEIGHT AND SIZE: a right battery must fit within the battery compartment of the quad and balance the plane correctly. For beginners, it is tempting to choose the biggest and most powerful battery the model can handle. But it will sacrifice flight performance and worst, if the battery voltage is too high it will destroy the ESC or motors. Check the ESC and motor specification to ensure right voltage pack and then, check the models center of gravity (CG) to decide on the right battery weight.

LI-PO CHARGING: never charge the battery above 4.2v per cell. Li-Po cells should not be discharged to below 3.0v. Li-Po batteries are significantly more volatile than the alkaline, NiCd or NiMH batteries also used for drones. Then, charging Li-Po batteries can result in fire. Do it in a safe area away from flammable materials and never unattended. Monitor the charging process. After flying and discharging the battery, allow it to cool to ambient temperature before recharging. To charge the battery, use only the correct and suitably compatible USB cable or an specific Li-Po battery charger. Discharging the battery too low can reduced power, flight duration or failure entirely. If suddenly the unit begins to require more throttle than typical to maintain hover, you should land the Quad and disconnect the battery immediately.

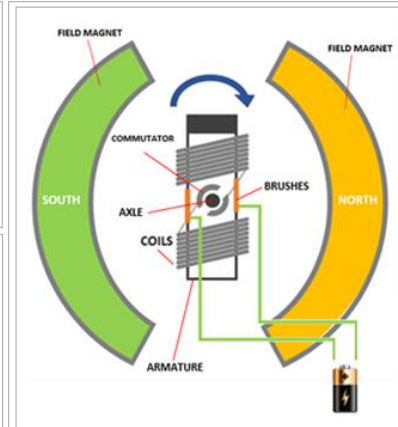

BRUSH MOTOR: positive and negative wires connect to power. There are two curved permanent magnets inside the case and a spinning shaft with wires wrapped around, it that goes down to the center of the motor. The shaft and the wires together are the armature of the motor and at one end is where the motor pinion gear is attached. At the other end there is the commutator. Touching the commutator to transfer electrical power to the armature are two brushes. The wires that come from the speedo (see diagram) bring power to the brushes which physically contact the commutator, turning the armature into a basic electromagnet field when electricity is applied.

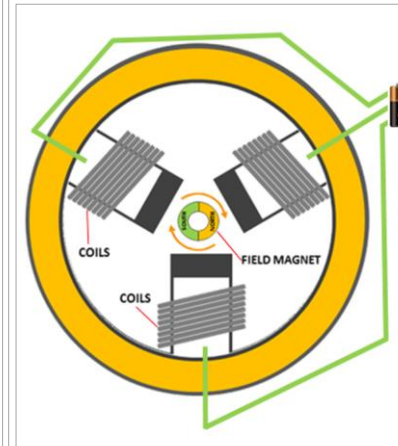

BRUSHLESS MOTOR are so much more efficient than brushed motors. When the rotor spins on, there is no physical connection at all, making the brushless motor more efficient and longer-lasting because there is no friction of the brushes and commutator. The speedo controls the rotation of the rotor also increases efficiency. There is no sparking from brushes to commutator so electrical interference is drastically reduced. Motor will stay cooler, boosting efficiency.

BRUSHLESS OUTRUNNER: It's a recent type of brushless motor. These motors have the rotor outside as part of a rotating outer case while the stator is located inside the rotor. This arrangement gives much higher torque than the conventional brushless motors, which means that outrunners are able to drive larger and more efficient propellers without the need of gearboxes.

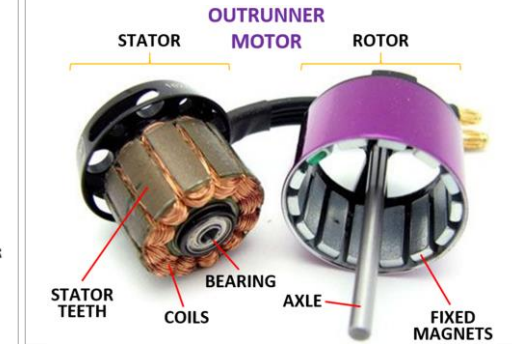
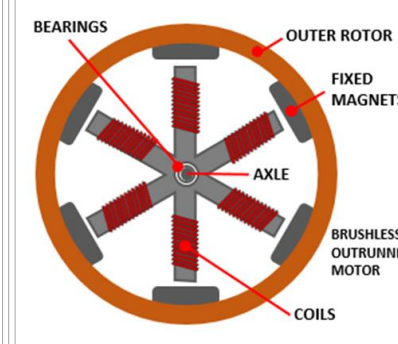



GPS & OTHER SENSORS: quadcopters have reached such a technologically advanced stage that many of them even have autopilot features that are guided by a GPS. In association with other sensors like 6-gyro, pressure, ultrasound, infrared and vertical camera, it's possible to deliver reliable flight stabilization for multi-rotors. The GPS module make possible some incredible capabilities as:

Self-Leveling: when the pilot releases the remote control sticks (pitch/roll), the quad remains stable at the same level.

Altitude Hold: the Quad have the ability to keep the distance from the ground with no throttle adjustment.

Return Home: when pressing a button, the Quad automatically return to the point where its initially took off.

Waypoint Navigation: the pilot can set specific points on a map that Quad will follow as part of a flight plan.

Fail Safe Returning Home: when the Quad lose contact with transmitter, for any reason and including low voltage from battery, its initiate a return to the initially took off point. It can also hold the altitude and position for a moment and starts a vertical landing procedure.

Circling Mode: a kind of geo-fencing that provides a virtual and safe box around pilots. It prevents the drone from flying too close of them.

Loiter Mode: when turned on, automatically attempts to maintain the current location, heading and altitude. It relies on the GPS locked before takeoff.

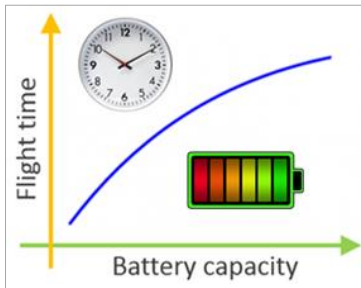

FLIGHT TIME VERSUS BATTERY CAPACITY:

using simple words, larger battery allows for longer Quad flight time. But the increase of flight time isn't proportional to the increase of battery size (see diagram). As the battery gets larger, the increase in flight time becomes ineffective. It will reach a point where it just doesn't gain any more flight time or even, lose it. This is mainly caused by the weight of the battery. Reducing weight is, indeed, the biggest key to extending flight times. Then, bigger and flatter propellers, higher-torque and lower-kv motors are other keys. But there are lots of other factors that contribute to reduce the Quad flight time. A few of them are wind speed, temperature, aerobatic maneuvers (flips and rolls), electronic components, quality of the link between Quad and transmitter. There are so many variables that it is almost impossible to specify exactly how long the quad will fly. Manufacturers use a time range to define the flight time. But this time is not always true and accurate fact. Thus, it can range from 5 to 25 minutes on Quads used for fun. Professional quads are a different story.



4) PHANTOM 2 VISION +: On-board built in Video Resolutions: 1080p (30fps or 60i) | Video Format: AVI | Photo Resolution: 14.0 MP | Optics: 140°, 110°, 85° wide angle | Memory: SD 4GB | Wi-Fi built in | 5.8 GHz video transmission. 5) PHANTOM 2 VISION: On-board built in | Video Resolutions: 1080p (30fps or 60i) | Video Format: AVI | Photo Resolution: 14.0 MP | Optics: 120°, 110°, 85° wide angle | Memory: SD 4GB | Wi-Fi built in | 5.8 GHz video transmission. 6) PHANTOMFC40: On-board built in | Video Resolutions: 720p (30 FPS) | Video Format: AVI | Photo Resolution: 720p | Optics: 100° wide angle | Memory: SD 4GB | Wi-Fi built in | 5.8 GHz video transmission. 7) AR.DRONE: On-board built in | Video Resolutions: 720p (30 FPS) | Video Format: H.264 codec (.mp4 file format) | Photo Resolution: 720p | Optics: 92° wide angle | Memory: SD card | Wi-Fi built in | 5.8 GHz video transmission.



CAMERAS FOR QUADS: There are several cameras used to record videos and take pictures using a Quad. Basically they can be higher or lower resolution according the needs (professional or just for fun).

HIGHER RESOLUTION – these cameras are mounted on special supports (gimbals) designed to stabilize the image. Examples are:

1) **GO-PRO HERO3+:** Add-on | Weight: 74 g | With housing: 136 g | Video Resolutions: 4K, 2.7K, 1440p, 1080p (Full HD), 960p, 720p (HD) & WVGA, variable FPS | Video Format: H.264 codec (.mp4 file format) | Photo Resolution: 12.0 MP | Optics: fixed f/2.8 aperture, ultra wide angle view | Rechargeable Li-Po battery | Memory: microSD card | Wi-Fi built in | 5.8 GHz video transmission.

2) **ILOOK:** Add-on | 76g (with antenna) | Video Resolution: HD 720p (30FPS) | Video Format: AVI | Photo Resolution: 1.0 MP | Memory: Micro SD card(max. 32GB) | Wi-Fi built in | 5.8 GHz video transmission. 3) **RC LOGGER PRO:** Add-on | Weight: 80 g | Video Resolutions: 720p (25 FPS) | Video Format: AVI | Photo Resolution: 5.0 MP | Optics: fixed f/2.8 aperture, ultra wide angle view | Rechargeable Li-Po battery | Memory: microSD card up to 32GB | Wi-Fi built in | 5.8

GHz video transmission. 4) PHANTOM 2 VISION +: On-board built in Video Resolutions: 1080p (30fps or 60i) | Video Format: AVI | Photo Resolution: 14.0 MP | Optics: 140°, 110°, 85° wide angle | Memory: SD 4GB | Wi-Fi built in | 5.8 GHz video transmission. 5) PHANTOM 2 VISION: On-board built in | Video Resolutions: 1080p (30fps or 60i) | Video Format: AVI | Photo Resolution: 14.0 MP | Optics: 120°, 110°, 85° wide angle | Memory: SD 4GB | Wi-Fi built in | 5.8 GHz video transmission. 6) PHANTOMFC40: On-board built in | Video Resolutions: 720p (30 FPS) | Video Format: AVI | Photo Resolution: 720p | Optics: 100° wide angle | Memory: SD 4GB | Wi-Fi built in | 5.8 GHz video transmission. 7) AR.DRONE: On-board built in | Video Resolutions: 720p (30 FPS) | Video Format: H.264 codec (.mp4 file format) | Photo Resolution: 720p | Optics: 92° wide angle | Memory: SD card | Wi-Fi built in | 5.8 GHz video transmission.

LOWER RESOLUTION – they are the smallest cameras found in the market. In general, these cameras have lower resolution and image quality when compared to cameras described above. However, because they are very lightweight, smaller drones usually use them.

Some examples are: 1) **WLtoys Part V959-16:** Video Resolutions: 0.3 MP | Dimensions: 6.1 x 2.2 x 1.9 cm | Weight: 8.0 g | Memory: 2GB Micro SD | Card Reader. 2) **Walkera TX 5885:** Video Resolutions: 0.2 MP (1280 x 720) | Definition: 420 TV-Lines | Dimensions: 4.8 x 2.2 x 9.5 cm | Weight: 8.0 g | Memory: 2GB Micro SD | Card Reader | 5.8G Image transmission. 3) **DV 04:** Video Resolution: 0,2 MP (1280 x 720) | Dimension: 4.4 x 3.6 x 1.0 cm | Weight: 14 g | Memory: 2GB Micro SD | Card Reader. Other one: **E-flite EFC-720** camera (Horizon Hobby Inc).

GIMBAL DIAGRAM

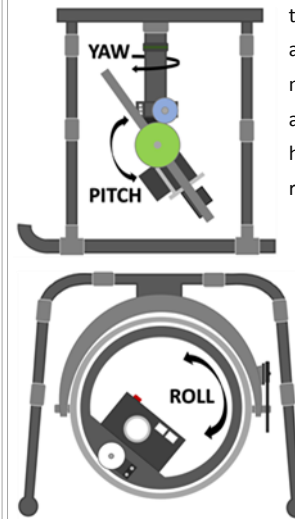

A **GIMBAL** for cameras is a pivoted support that allows the rotation (roll, pitch and yaw) of an object and also allows an object mounted to remain independent of the movements of its support, keeping the camera pointed at the same place despite motion of the Quad flight. It highly improves image quality and stability when recording videos and photos.

A gimbal basically counteracts changes in the aircraft's movements to keep the camera as steady as possible. For example: 1) When the Quad suddenly pitches down due to a headwind, the gimbal will pitch (tilt) up a bit to compensate. 2) If the aircraft rotate a bit, gimbal set will counteract this motion by rolling a bit in reverse to negate this motion. 3) If there is a pitch and a roll at the same time a bit of the yaw component will be needed to counteract this complex motion and keep things aligned. There is available at the market, 2D and 3D gimbals. The 3D set can compensate for motion in all three axes (roll, pitch and yaw) whereas the 2D can only compensate for motion in roll and pitch (see diagram above). Results of video capturing with the 2D on pan moves, tend to be more shaken when comparing to 3D gimbal that provides smoother horizontal movements, giving more professional look to video recording. The 3D has an extra added motor to the top to control the yaw. See examples below:



RTF (Ready-to-Fly): the model comes complete, nothing is needed to get started straight from the box.

BNF (Bind-N-Fly): products come without the transmitter. Use own transmitter. Bind it to the receiver.

PNP (Plug-N-Play): product comes with everything, except for, transmitter, receiver, battery and charger.

ARF (Almost-Ready-to-Fly): the model needs some additional items before you can start flying. See the box label.

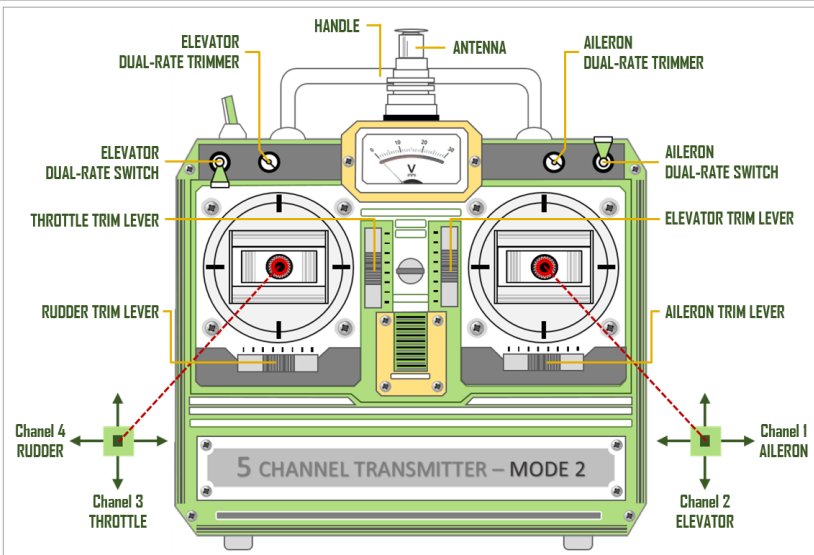

REMOTE CONTROL: before buying a Quad, the RC Transmitter is the first thing to look at, mainly if the chosen product is a BNF (Bind-N-Fly) or PNP (Plug-N-Play). The basics are:

1) RC TRANSMITTER: price range a lot. It's possible to buy one from U\$40.00 to over U\$1,000.00 depending on the number of channels and features that it has. Each channel allows one individual action on the aircraft that can be controlled. It's something like one channel for throttle, one channel for turning right and left, one channel for pitching forward and backward, one for rolling left and right. Four channels are the minimum for a Quad. With more channels it's possible to have switches to change settings while flying. Some specialists recommend using transmitters that have at least 5 channels. The extra channels are useful for switch among different flying modes (see example diagram above). Other experts say that Quads guided by GPS require at least an 8 channels transmitter.

2) MODES: there are two different modes, mode 1 and mode 2. Basically, it's different configuration for each stick. The mode 1 configuration has the elevator control on the left joystick and the throttle on the right one. The mode 2 is the most easy and common for Quads because the stick represents the movement of the aircraft. It has the elevator control on the right joystick and the motor throttle on the left one. The right joystick self-center in the both axis, whereas the left joystick only self-center in left | right axis and clicks in the up | down axis in order to allow the throttle setting.



3) **RECEIVER** piece usually build in the drone or comes with the transmitter when purchased. Some types of transmitters are only compatible to their own receivers brand. There are exceptions to be paired with other receivers but pay attention on that issue. Currently, transmitters use the band 2.4GHz, **DSS (digital spread-spectrum)** protocol in two different types **FHSS** and **DSSS**.

FHSS (Frequency-Hopping Spread-Spectrum): transmits within a specific frequency band but changes the precise frequency of the transmission hundreds of times a second trying to reach interference immunity. **DSSS** (Direct Sequence Spread Spectrum): uses random PN code sequences and picks one or more pseudo randomly selected frequencies out within the band. With several randomly selected frequencies, along with random code sequences, it's very unlikely all of them would ever experience interference at the exact same time, also trying to achieve interference immunity. There are other band modulation methods used for RC aircrafts like **AM, FM/PPM and PCM**. All these modulations use narrow band radio transmission. They transmit a signal on a specific frequency within the radio spectrum. Pilot needs to tune into an exact same specific frequency both, receiver and transmitter. RC métier uses radio frequencies in the 27 to 75 MHz range. Most hobby grade RC aircraft use the 72 & 75 MHz band range of the radio spectrum.

AM: the first method used for controlling RC models. It sends information to the model by changing the amplitudes of carrier wave at a specific frequency. The receiver then filter the highs and lows of the changing amplitudes of the carrier wave into usable information. But this method is easily affected by almost any electrical noise and much interference issues occurs. **FM & PPM** (Frequency Modulation and Pulse Position Modulation) methods on RC market belongs to 80's. **FM** sends information by changing the frequency of the radio wave instead of the amplitude. However, the Quad itself can generate electrical noise and the receiver can interpret this own noise as a true signal causing, in the worst cases, aircraft control loss. **PCM** (Pulse Code Modulation) works by embedding a digital signal within the FM radio wave. A chip build in the RC transmitter will encode a digital transmission and send it out as a FM wave. The receiver decodes that digital data back into an analog signal. Some experts say that PCM method have a fail-safe feature. If the receiver doesn't understands the radio signal it will move automatically the servos to throttle off and all other controls to neutral. It's not a feature like fail-safe-landing executed by Quads with GPS. But it will helps keeping control of the aircraft. A few RC Transmitter examples are:



#	RC Transmitter Brand	Website
1	Airtronics	http://www.airtronics.net/
2	FlySky (FS)	http://www.flysky-cn.com/eindex.asp
3	Futaba	http://www.futaba-rc.com/index.html
4	Hitec	http://hitecrctd.com/
5	JR Propor	http://www.iramericas.com/
6	Spektrum	http://www.spektrumrc.com/
7	Tatics	http://www.tacticrc.com/transmitters/
8	Turnigy	http://www.turnigy.com/
9	Walkera	http://www.walkera.com/en/



TELEMETRY: adding wireless telemetry to the Quad, it will greatly extend the capabilities of the aircraft. It's possible to view data as live FPV Video, Link Quality, Bearing, Altitude, Climb Rate, Speed, Velocity, Temperature, Latitude & Longitude, etc.

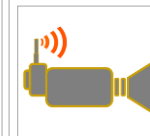

FPV (FIRST PERSON VIEW) is a method used to control RC aircrafts from the pilot point of view. The vehicle is driven remotely from a first-person perspective via an onboard camera fed wirelessly a video monitor, a tablet or a mobile phone. A basic FPV system consists of a camera and a video transmitter on the aircraft, with a video receiver on the ground. FPV aircraft are frequently used for aerial photography and videography. Many lightweight high-definition cameras can be carried by Quads and they are also able to connect via Wi-Fi. Go-Pro and Walkera Ilook are two examples. An upmarket aircraft can also carry a gimbaled camera and GPS navigation module to create a truly immersive first-person experience, as if the pilot was really sitting in the cockpit of the RC aircraft.

VIDEO DOWNLINK sets for RC aircrafts are current available in the market. There are revolutionary Full HD digital video downlink equipment extremely powerful and packed into small and lightweight cases. Some of them offer 1920 x 1080 (30fps) video data transmission from up to 1.0 km. Of course, there are less sophisticated systems that offer lower resolution video, for smaller distances at more affordable prices. It includes some small quads as Hubsan X4 H107D and small cameras as Walkera TX 5885 built in with a 5.8 GHz video transmitter. When controlling an aircraft with a 2.4GHz RC transmitter, the best option will be using a 5.8GHz for video downlink. This way, it's possible to avoid interference between both systems.



APP AVAILABILITY: This type of app is free and provided by the aircraft manufacturer. Usually it's compatible with devices running IOS, Android and Windows Phone, and allow to remotely control the Quad using a smartphone or tablet, substituting the use of a RC transmitter. It connects through Bluetooth to the Quad. Once on the first screen, the pilot can access all functionalities as piloting, photos and videos, flight plan, altitude, speed, etc.

PHANTOM

dji THE FUTURE OF POSSIBLE



YOUR FLYING CAMERA	PHANTOM 2 VISION+	PHANTOM 2 VISION	PHANTOM 2	PHANTOM FC40
Stabilization Gimbal	3-axis Camera Stabilization Gimbal U\$ 1,299.00	None U\$ 999.00	Add on U\$ 680.00	None U\$ 500.00
Video Downlink	Max 700m Wi-Fi Connection	Max 300m Wi-Fi Connection	Add on	—
APP	DJI VISION App	DJI VISION App	None	DJI FC40 App
Camera	14 Megapixels/1080p	14 Megapixels/1080p	Add on	720P
Controllable Range	-90°-0° (Vertical)	-60°-0° (Vertical)	—	None
Remote Controller	800m (FCC), 5.8Ghz preinstalled smartphone holder	800m (FCC), 5.8Ghz smartphone holder in pack	1000m (FCC&CE), 2.4Ghz without smartphone holder	800m (FCC), 5.8Ghz smartphone holder in pack
Max Flight Time	25mins	25mins	25mins	15mins



CAMERA PARAMETERS

Camera settings including Picture Quality, ISO, Exposure Compensation, White Balance, and format can be adjusted through the Vision app.

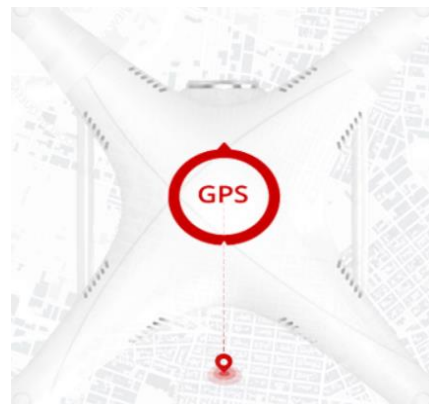

RADAR POSITIONING & RETURN HOME

The flight radar displays the current position of the Phantom 2 Vision+ in relation to the pilot. Exceeding the control range of the remote control will trigger 'Return-to-Home'. The Phantom 2 Vision+ will automatically fly back to its takeoff point and land safely.

PRECISION FLIGHT AND STABLE HOVERING

The integrated GPS auto-pilot system offers position holding, provides altitude lock along with stable hovering giving you constant stable flights so you can focus on getting the shots.

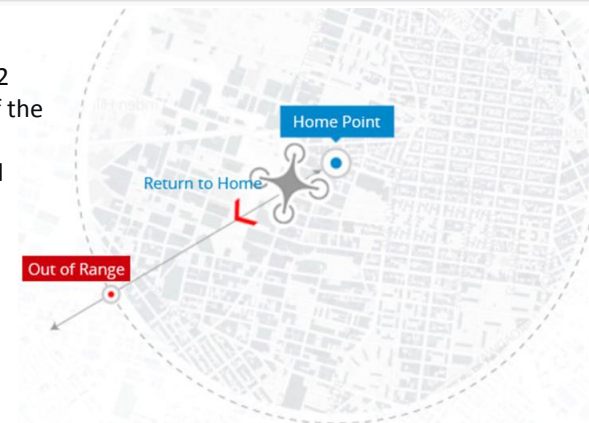



- ### FLIGHT RECORDER
- Geolocation using the GPS module.
 - Select your destination on the map.
 - Record flights and videos using 4 Gb Flash memories.
 - Make the AR.Drone 2.0 automatically return to its take-off point.
 - **CLICK & GO:** Select the destination on the map, set the altitude and cruise speed, push "GO". The AR.Drone starts its flight!

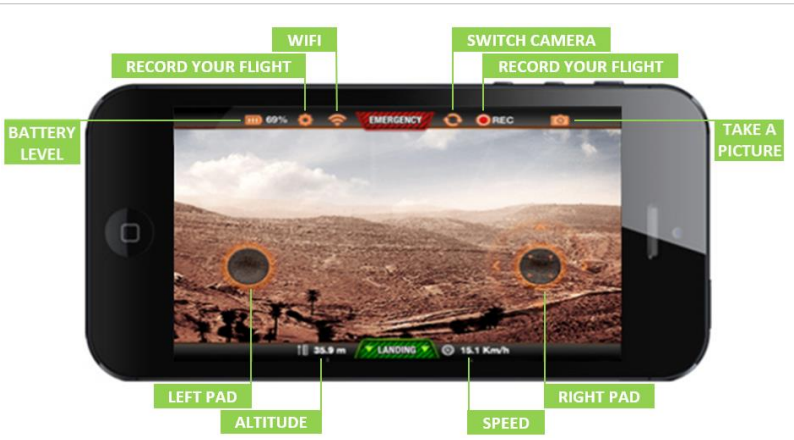

- ### "IMPRESSIVE, INTUITIVE!"
- AR.FreeFlight is the primary application used to fly and pilot the AR.DRONE.
 - Pilot with or without the accelerometer and switch from the frontal/vertical camera.
 - Record pictures, nav data & videos and upload them instantly right from the application.
 - New user friendly interface.

- ### ELETRONIC ASSISTANCE
- Automatic stabilization features.
 - Chip 1GHz, 32 bit ARM Cortex A8 | Linux 2.6.32.
 - 1GB DDR2 RAM | USB 2.0 high speed | Wi-Fi b g n.
 - Ultrasound sensors for ground altitude measurement.

- ### MOTORS
- Brushless inrunner motors (14.5W-28,500 rpm).
 - Emergency stop controlled by software.
 - Fully reprogrammable motor controller.
 - Water resistant motor's electronic controller.

- ### ROBUST STRUCTURE
- Carbon fiber tubes : weight 380g outdoor | 420g indoor.
 - High grade 30% fiber charged nylon plastic parts.
 - Foam isolates body from the engines' vibration.
 - All parts and instructions for repairing available.

FLY HIGHER

Thanks to the Wi-Fi connection of the Drone and the GPS Flight Recorder, range increases up to 50m.

RETURN HOME MODE

Making the Drone return to its take-off point is now child's play thanks to this new feature.

- ### HD CAMERA
- 720p - 30FPS - H264 encoding base profile.
 - Low latency streaming.
 - Video storage on the fly with remote device or with USB flash drive.
 - JPEG photo capture .
 - As you fly, the HD video is recorded and sent directly to your device.

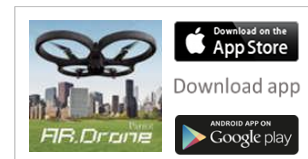
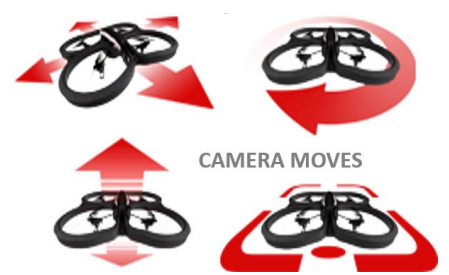

GPS Edition	U\$ 460.00
Power Edition	U\$ 350.00
Elite Edition	U\$ 300.00

Parrot

BEBOP DRONE

+SKYCONTROLLER

(Announced)



SKYCONTROLLER

Equipped with an amplified Wi-Fi 36 dBm radio and with four antennas, the unit extends the Wi-Fi range up to 2kms. The piloting smartphone or tablet is fixed on a shelf. The pilot takes control of the drone via two ultra precise joysticks. For extreme view (sensations), it is possible to connect First Person View glasses to the unit with the HDMI.

REINFORCED STRUCTURE

The feather-weight ABS reinforced structure makes Bebop robust and safe. In case of emergency, propellers automatically stop. The emergency mode enables the Drone to land immediately. Thanks to GPS, a Return Home function brings the Bebop drone back to its take-off point. EPP hulls are included in the pack.

BEST PERFORMANCE

The Bebop have a battery life 8 times more powerful than Parrot AR.Drone 2.0. It have an onboard navigation computer P7 dual-core CPU, quad-core GPU and 8 GB of Flash Memory.

ASTOUNDIBGLY STABLE

To ensure an optimal stability without compromising the maneuverability, the Bebop Drone analyzes data from numerous sensors automatically: 3-axes accelerometer, gyroscope, magnetometer. one ultrasound sensor with an 8 meters reach, one pressure sensor and a vertical camera to track the speed.

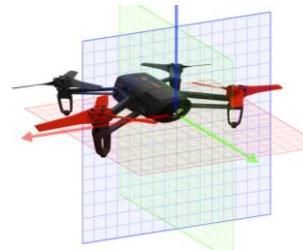

FREEFLIGHT 3.0 INTUITIVE APP

The Bebop comes with a piloting application for iOS and Android Smartphones or tablets. Once on the welcome screen, the pilot can access the functionalities: Piloting, photos and videos, flight plan, altitude and speed, piloting mode (accelerometer, virtual joystick, etc.) and features such as one-touch Flip.



Parrot

ROLLING SPIDER

(Announced)



AUTOPILOT
SENSORS

Pressure for the flight altitude.
Ultrasonic for flying near the ground.
Vertical camera (measures speed).



BATTERY



REMOVABLE WHEELS



STICKERS



FREE FLIGHT 3 FREE APP offers an intuitive control from your smartphone or tablet. It connects through Bluetooth Smart to your Rolling Spider. It is compatible with devices running iOS, Android, Windows Phone 8.1.



INDOR-OUTDOOR



18 km/h

FLIPS

360°

RANGE

20 m

PHOTOS

300,000 PX



SMARTPHONE
CONTROL



FLIGHT

8
MIN





UDI U818A

U\$ 90.00



DESCRIPTION

- Battery: 3.7V 500mAh Li-Po battery (included).
- Charging Time: 120 minutes.
- Flying time: 6-9 minutes.
- Controlling Distance: 100 meters.
- Battery For Controller: 4 x AA batteries.
- Product Size: 33 x 34 x 5.5cm.
- Function: 360°flips.
- Video recording | Photographing.

FEATURES

- 2.4G 4CH RC 6-axis UFO.
- Equipped with Camera and Gyro.
- Transmitter with LCD display.
- English manual.

PACKAGE INCLUDES

- 1 x U818A RC Quadcopter
- 1 x transmitter
- 1 x battery | 1 x USB cable
- 4 x blades
- 1 x manual



TRANSMITTER 2,4 Ghz



CAM SET



UDI U816A

U\$ 70.00



PACKAGE INCLUDES

- 4 Channel 2.4Ghz Remote controller
- 100% Pre-assembled UFO Body w/6-Axis Gyro
- 1 X Li-Po Battery | 1 X Spare Orange Canopy
- 4pcs Main Rotor Blade | 1 X Screw Driver
- 1 X Battery Charger (Charger from USB cable)

DESCRIPTION

Size (Motor to Motor) : 12,5 cm
 Length : 16,5 cm | Height : 9,5 cm | Width : 16,5 cm
 Gyro 6-Axis (Built in) | Battery : 3.7V Lipo Battery
 Transmitter: 4 x 1.5V AA dry cells | Channel : 4-Ch
 Radio Distance : 30m | Charging time : 60mins
 Flight time : 6-10 minutes



TRANSMITTER 2,4 Ghz





Hubsan X4
H107D

US\$ 150.00



DESCRIPTION

- Transmitter: 2.4GHz 4 channels vs 4.3 Inch LCD.
- Control distance: 50 - 100meters.
- Live video distance: 100 m.
- Battery: 3.7V 380mAh li-po battery.
- (auto cut off safety PCB).
- Charging time: about 30 minutes.
- Flight time: around 7 minutes.
- Camera: 0.3MP | Resolution: 640 x 480.
- Memory card: SD card Micro SDHC class6 2-16G.

FEATURES

- Instant video review on transmitter.
- Six-axis flight control system.
- Adjustable gyro sensitivity | Super stable flight.
- Outdoor and indoor flight.
- Four night LED lights & rubber feet.
- USB charging cable (by computer or wall charger).

PACKAGE INCLUDES

- 1 x Hubsan H107D RC Quadcopter
- 1 x 5.8g transmitter
- 1 x Li-Po battery
- 1 x USB charging cable
- 4 x spare blades



2.4GHz + 5.8GHz
(Video transmission)



H109S X4 PRO
(Announced)



DESCRIPTION

- Battery: 11.1V 7000 mAh Lipo battery.
- Flight time: around 30 min.
- Transmitter frequency: 2.4GHz/ 5.8GHz.
- Video distance: 300-2000 m (antennas with different range).
- Motor to motor distance: 26.0 cm.

FEATURES

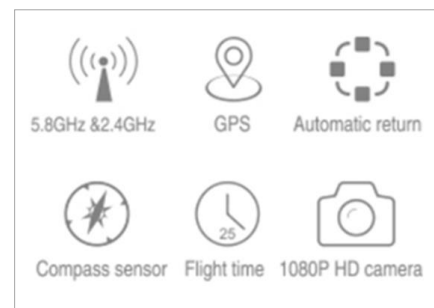

- Precise aerodynamic light weight design.
- Super strong PC plastic material body design.
- Gopro 5.8Ghz live video without latency (5.8Ghz VTX).
- Clover leaf and patch antennas exchangeable design.
- Fatshark goggles compatible | 3D Camera Gimbal.
- Wireless Upgradable design for future update.
- Customer preference setting adjustable on TX.
- Multifunctional landing gear | GPS RTH | Headless mode.
- Barometer altitude hold | Safe return to home mode.



PACKAGE INCLUDES

- 1 X Hubsan H109S X4 PRO Quadcopter.
- 1 x Transmitter.



Galaxy Visitor 2

U\$ 130.00



FEATURES

- Headless Flying under intelligent control (extremely easy for beginner).
- Auto-Return function (safety guard against lose control).
- Brake function | Anti-crash protector.
- Switch on/off of accelerometer.
- On board micro digital video | picture camera.

DESCRIPTION

- Length: 12.3 cm | Width: 10.2 cm.
- Height: 4.6 cm | Weight: 44g.
- Transmitter: JFG 2.4GHz 4CH.
- Battery: 3.7V 300mAh Li-PO.
- Four Coreless motors.
- Blade fixed pitch.
- Flight time: 8 minutes.
- Charging time: 30 min.
- Video camera: onboard.



PACKAGE INCLUDES

- 1 x Galaxy Visitor Quadcopter With Camera.
- 1 x 3.7V 350mAh Li-Polymer Battery.
- 1 x USB Charger | 1 x 2.4 GHz 4CH Transmitter.
- 4 x Spare propellers | 4 x Propeller guard rings.
- 1 x Micro SD Card 2GB | 1 x SD Card Reader.
- 1 x Screwdriver | 1 x Manual (instruction).



Galaxy Visitor 3

U\$ 160.00



FEATURES

- Headless Flying under intelligent control (extremely easy for beginner).
- Auto-Return function (safety guard against lose control).
- Brake function | Anti-crash protector.
- Switch on/off of accelerometer.
- On board micro digital video | picture camera.

DESCRIPTION

- Gyro sensor: 9 Axis.
- Power system: 8.5 coreless motor.
- Battery : 3.7V 1200mAh Li-Po.
- Flying time: 15min – 20 min.
- Control distance: 100 – 200 m.
- Dimension: 16.3 cm x 16.3 cm x 7.8 cm.
- Weight: 135g.

PACKAGE INCLUDES

- 1 x Galaxy Visitor 3.
- 1 x JFN Transmitter.
- 1 x Adapter.
- 1 x Charger.
- 1 x Lipo Battery.
- 1 x 2GB SD card.
- 1 x Card Reader.
- 4 x Propeller.
- 1 x Manual.



Walkera QR X350 Pro (Cheerson CX-20 Auto-Pathfinder)

U\$ 320.00



PACKAGE INCLUDES

- 1 x Quad | 4 x Spare propellers.
- 1 x DEVO 10 | 1 x Charger.
- 1 x Battery: 11.1V, 5200mAh Li-Po.

DESCRIPTION

- Length: 28.9 cm | Width: 28.9 cm.
- Height: 20.0 cm | Flight Time: 25 minutes.



GPS Auto
Pilot Function



Come Home
Button

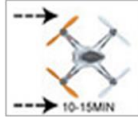

10 – 15 min.
Flight



Altitude
Sensor (GPS)

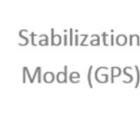

Stabilization
Mode (GPS)

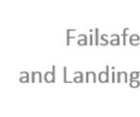

Failsafe
and Landing

Professional 10 Channel
PRO control range: 2000 m.
WiFi image range: 400 m.

FEATURES

- Improved precision flight control system.
- Enhanced GPS position holding.
- Altitude sensor | Compass sensor.
- G-2D brushless camera gimbal (iLook or GoPro).
- One Key "Return to Home".
- Stable mode with GPS and altitude hold.
- Failsafe to return home & landing.
- Low voltage protection.
- DEVO 10 transmitter with 2 km control range.
- Easy to see LEDs.



Low Voltage Protection
Receive the signal on low battery



7 Channel PRO

Walkera QR X400

U\$ 380.00



FEATURES

- Four brushless motors provides a stable flight including 3D rolls and flips.
- Compact modularized design provides easy installation and maintenance.
- Six-Axis gyro control system ensures precise flight performance.
- Camera set for aerial photography (sold separately).
- Telemetry module monitor (sold separately).
- Extra-large capacity battery.



U\$ 60.00

TELEMETRY MODULE SET

Walkera WK-CTL01-D
Working voltage 5-6V.
4 temperature sensor ports.
3 voltage testing ports.
2 RPM ports (sensor not included).
1 GPS port (GPS module not included).



U\$ 40.00

WK-GPS GPS SENSOR

for Walkera Telemetry Module



U\$ 40.00
CAMERA SET

PACKAGE INCLUDES

- 1 x UFO QR X400 Quadcopter.
- 1 x 10CH DEVO 7 Transmitter.
- 1 x Battery Charger.
- 1 x 11.1V 2200mAh Li-Po Battery.
- 1 x Aluminum Carry Case.
- 4 x Main Rotor.
- 4 x Landing Skid.
- 1 x Manual.

Walkera QR Infra X

U\$ 160.00



FEATURES

- 6-Axis stabilizing system (stable flight).
- IOA system to avoid the obstacles automatically (infrared).
- Ultrasonic Altitude system keeps flight at relative height.
- Amazing curves using Aileron and Elevator (no Rudder).
- Perfect flyer for professional pilots or beginners.

DESCRIPTION

- Dimensions: 10.8 cm x 10.8cm.
- Height: 6.2 cm.
- Weight: 73g (total).
- Battery: 3.7V 600mAh
- Radio range: 100m.
- Flight time: 7min.
- Selectable radio:
- DEVO 6/7/8S/10/12S



Transmitter 2.4GHz

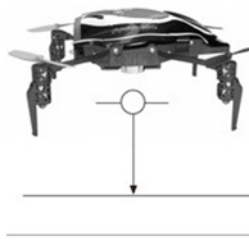

When quad reach 0.2 to 2.0 meters far from the ground, leave the throttle stick alone and the unit can still fly at the same altitude.

INFRARED SENSOR

OBSTACLES AVOIDANCE

Walkera Ladybird V2 FPV

U\$ 170.00



DESCRIPTION

Receiver: RX2643H-D (for DEVO TX).
Battery: 3.7V 240Mah.
Dimension: 10.0 x 10.0 cm.
Height: 3cm.
Flight distance: 30 m.
Flight time: 9-10 min.

PACKAGE INCLUDES

1 x Walkera Lady Bird V2 with TX 5805 Cam.
1 x Walkera Devo F4 FPV Transmitter.
1 x 3.7V 240mAh Li-Polymer Battery.
1 x Charger | 1 x Manual.

Pixels: 200 mega pixel | PAL-NTSC
Resolution: 1280x 720 | Color
Definition: 420 TVL | Weight: 8g
Dimension: 48 x 22 x 9.5mm

The canopy is made of supple and stable material and won't be break by falling and crashing

Plastic propellers use supple material and won't be break due to collision

Motor sleeve can protect motor from damaging due to collision.

Feet rubber is protective while falling



Devo F4 Transmitter (2.4 GHz)
Image Receive: 5.8G





Walkera UFO MX400S

U\$ 330.00



DESCRIPTION

- Dimensions: 27.0 cm x 27.0 cm.
- Height: 19.0 cm.
- Weight: 786 g (w/o battery).
- Battery: 11.1V 2200mAh Li-Po 25C.
- Transmitter: DEVO 7/8/9/10.

PACKAGE INCLUDED

- UFO-MX400 Body.
- LED Light Decoration Set.
- 11.1V 2200mAh Lipo Battery.
- AC Battery Charger.
- DSC Cable | Bind Plug.
- English Manual.

FEATURES

- 6-axis control makes the flight super stable.
- Flashing LED lighting for outstanding visibility.
- Stylish high performance light weight skid landing.
- Upgradable for telemetry functions.
- Upgradable to GPS functions.



UP02 adapter to update the receiver firmware from Walkera website.



2.4Ghz DSSS Transmitter
7-Channel



Walkera QR W100S

U\$ 110.00



FEATURES

- Can be flown via WIFI (works with iPads/iPhones).
- Control range remained unchanged at 80 meters.
- The controls are very smooth and sensitive.
- Real-time first person view on the iPhone or iPad.
- Six Axis Gyro for enhanced control system.
- 30W pixel HD camera included.
- Gravity sensor to improve controls and flight stability.
- Enhanced ratio gear structure with upgraded motor.

DESCRIPTION

- Size: 14.4 cm x 14.4 cm.
- Height: 4.4 cm.
- Wi-Fi Range: around 80m.
- Flight time: 6-7min

PACKAGE INCLUDES

- 1 x Walkera QR W100S WIFI.
- 1 x DEVO 4 Transmitter
- 1 x Battery Charger
- 1 x 30W pixel HD camera
- 1 x 3.7V 600mAh Li-Po Battery
- Manual (In a CD-ROM)

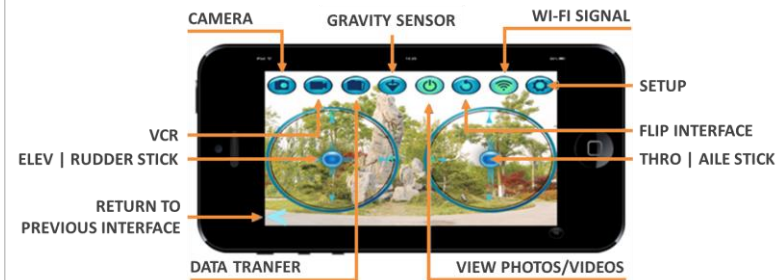

WIFI ANTENNA

HD CAMERA
30W pixel



Walkera HM Hoten X

U\$ 230.00



PACKAGE INCLUDES

- 1 x Quad.
- 1 x 7.4V, 1000mah, Li-Po.
- 1 x Battery charger.
- 4 x Spare blades.
- 2 x Battery cable adapters.
- 1 x User Manual on a CD.

DESCRIPTION

- Weight: 332.3 g.
- Transmitter: DEVO 7.
- Gyro: 6 Axis Gyro.
- Dimensions: 26.5 cm x 26.5 cm.
- Brushless motor.
- Battery: 7.4V 1000mAh Li-Po.
- Environment: Outdoor.
- Experience Level: Intermediate.
- The RX firmware can Update Online (cable & adapter optional).
- Telemetry Function(optional).

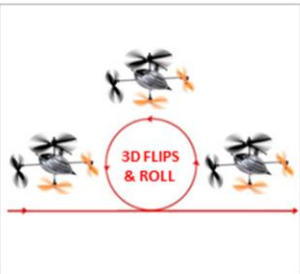

ON BOARD MICRO CAMERA



Blade 350 QX

U\$ 470.00

BLADE
#1 BY DESIGN

DESCRIPTION

- Rotor Ø: 58.0 cm.
- Weight: 680 g.
- Length: 46.5 cm.
- Width: 46.5 cm.
- Brushless 1100 Kv.
- Kit/ARF/RTF: RTF
- Blade Length: 21.0 cm.
- Flight time: 10 – 15 m.
- Indoor/Outdoor.



SMART MODE

While in Smart Mode, technology engages the innovative SAFE circle™ which prevents the drone from flying too close to the pilot.



RETURN HOME

During Flight, with the flip of a switch and without any stick input from the pilot, the drone will automatically return home to where its motor were started.



STICK RELATIVITY

Move the cyclic stick on the transmitter right or left, and the drone will move right or left relative to de pilot regardless of each way it's pointing.



AGILITY MODE

While flying in Agility Mode, the drone can perform aerobatic maneuvers with extreme stability thanks to SAFE technology.



SAFE CIRCLE™

While in Smart Mode, technology engages the innovative SAFE circle™ which prevents the drone from flying too close to the pilot.



GPS & ALTIMETER TECHNOLOGY

During Flight, with the flip of a switch and without any stick input from the pilot, the drone will automatically return home to where its motor were started.



STABILITY MODE

Move the cyclic stick on the transmitter right or left, and the drone will move right or left relative to de pilot regardless of each way it's pointing.

SMART MODE ALTITUDE CONTROL





BUBBLE BLOWER



WATER CANNON



MISSILE LAUNCHER



HOOK E BASKET

VLTOYS
V959
U\$ 80.00



FEATURES

- Remote Control for Flying, 360° rotating, video & photo catch.
- With 2.4G Transmitter with easy adjust frequency rave.
- Searching Lights, 2 front and 2 back lights.
- Scale remote control with built-in GYRO System.

DESCRIPTION

- Flight Duration: 8-10 min.
- Control Distance: 100 - 150 m.
- Recharging Time: 1 - 1.5 hours.
- Li-Poly battery 3.7V 500MAH.

PACKAGE INCLUDES

- 1 x Quad Copter with Camera
- 1 x 2.4G Transmitter with LCD.
- 1 x 3.7V 500mAh Li-Po Battery
- 1 x Charger
- 1 x Micro SD Card 2G Volume
- 1 x Card Reader.
- 4 x Main Blade.
- 1 x Operation Manual.



Transmitter 2.4GHz



VLTOYS V262
(Cyclone)

U\$ 90.00



FEATURES

- Four rotors are driven by 4 motors.
- Motors protected in plastic housings.
- Rotors are gear driven.
- Less stress on the motors.
- Rotor blades protected by a molded foam shell.
- Foam shells absorb impacts and protect the blades.
- Foam shells protect drone on collisions.
- On board gyro and adjustable control sensitivity.

DESCRIPTION

- 2.4Ghz 4-Channel remote with built-in LCD display.
- 7.4v 850mAh Rechargeable Li-Po battery.
- Flying time: 8 - 10 min | Charging time: 60 - 90 min.
- Operating range: 150 m | Measures: 55 cm x 55 cm x 5cm.

PACKAGE INCLUDES

- 1 x V262 Quad | 4ch 2.4Ghz Transmitter | Charging adapter.
- 4 x Spare Blades | 1 x Li-Po Battery | Instruction Manual.



Transmitter 2.4GHz

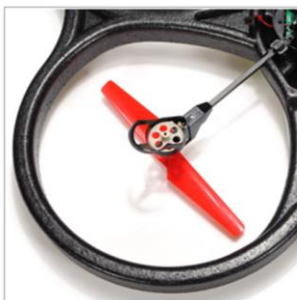



WLtoys V303 Seeker

U\$ 420.00



DESCRIPTION

- Channel: 4CH | Remote Control: 2.4 Ghz.
- Size: 30.5 cm x 30.5 cm x 18.5 cm
- Flight time: 13 - 15 min. | Charging time: 60 - 100 min.
- Flight weight: 800 g | Control distance: 500 m.
- Motor: 4pcs 2212 950kv motor
- Battery: Li-Po battery 11.1V 2700MAH 25C.

FEATURES

- Six-axis system | GPS Auto Pilot Function | Come Home Button.
- Low voltage protection | Failsafe and Self Landing | Set high mode.
- CF headless mode | PTZ gyro-stabilized | Wifi FPV 300 m.
- Gopro camera mount (Camera not included).
- Upgradable configuration.

PACKAGE INCLUDES

- 1 x WL V303 RC Quad.
- 1 x USB Charger.
- 1 x Transmitter.
- 4 x Main Blade.
- 1 x Operation Manual.

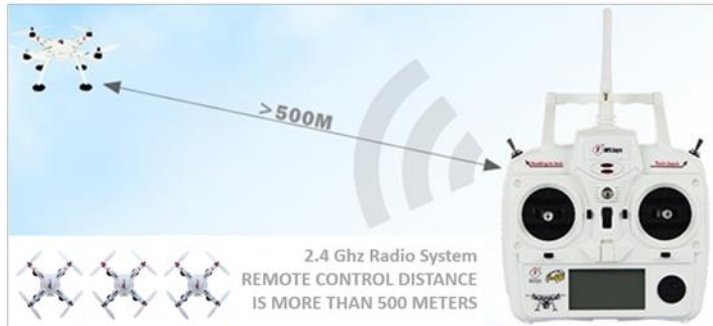

LotusRC T380

U\$ 220.00

LotusRC

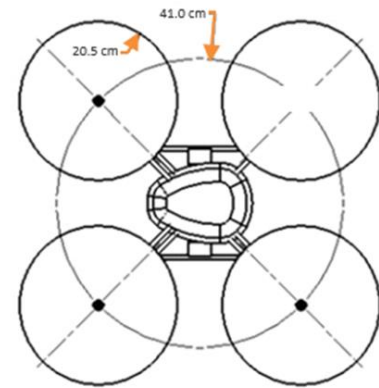
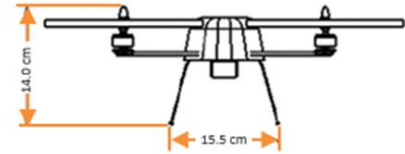

FEATURE

- High efficiency 8inch slow fly propellers and brushless motors.
- High-performance sensor for auto level stabilization.
- Compatible with all standard RC transmitters.
- Easy to setup: install propellers and plug cable to receiver.
- The T380 supports altitude hold to assist stable flight.

DESCRIPTION

- Aircraft size: 41.0 cm x 41.0 cm x 14.0 cm.
- Size with props: 61.5 cm x 61.5 cm x 14.0 cm.
- Aircraft weight (kit only): 430 g | Take-off weight: 610 g.
- Flight distance: visual area

PACKAGE INCLUDES

- Lotus T380 RC Quad.
- Transmitter + Receiver (Not Included)
- Battery: 25C 11.1 V 1200 mAh Li-Po
- Balance Charger (Not Included) | Manual





TRAXXAS QR-1 Quad-Rotor

US\$ 60.00



FEATURES

- Quad-rotor thrust with digital 6-axis stabilization.
- Quickly master stable hovering and flight in Normal mode.
- Perform flips, snap rolls, and banking turns in Expert mode.
- Two blue LEDs light the way | genuine accessories available.

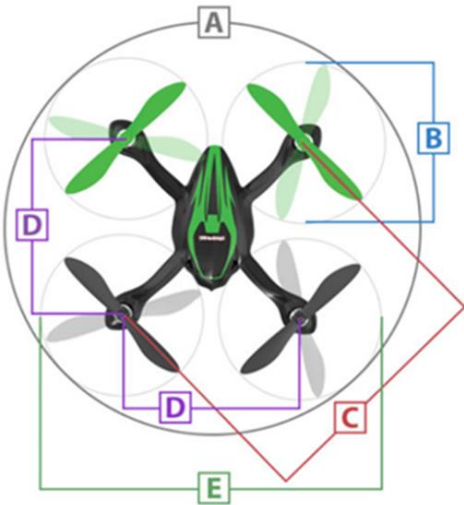

- A** 14.7 cm
- B** 55.0 cm
- C** 92.0 cm
- D** 65.0 cm
- E** 12.0 cm

DESCRIPTION

- Length: 12.0 cm | Width: 12.0 cm.
- Rotor Diameter: 5.5 cm | Blade Circle: 14.7 cm.
- Weight: 33g | Height (overall): 2.8 cm.
- Stabilization: Six-Axis.
- Transmitter: 2.4GHz 4-channel.
- Structure: Molded composite.

PACKAGE INCLUDES

- 2 x 1-Cell 240mAh Li-Po (3.7 volts) battery.
- 1 x USB charger.
- 4 x Spare rotor blade.



TRAXXAS ALIAS

US\$ 170.00



FEATURES

- A 2.4Ghz transmitter, designed with precision gimbals.
- A LCD display provides flight information.
- Transmitter: digital trim and an internal antenna.
- Three flight modes, programmed on mode transmitter.
- Auto leveling six axis flight system.
- Unit returns back to level flight when sticks are released.
- Rotors: unique manufacturing method for perfect balance.
- Unit includes high grade metric hex drive hardware.
- Constructed with soft rubber to cushion impacts.
- Four brushed coreless motors assembled and ready to fly.
- Flight Time: 15 Minutes



EASY
Flight angles are limited



FAST
Full speed potential is unlocked enabling aerobatics



EXPERT
Disable the auto-leveling allowing full manual control

DESCRIPTION

- Blade Circle: 37.5 cm.
- Rotor Diameter: 14.0 cm.
- Width: 30.7 cm.
- Ground Clearance: 11.9 cm.
- Overall Flight Weight (with battery): 100g
- Battery Voltage: 3.7V





The technology integrates data received from a 3-axis gyro and a 3-axis accelerometer then compensates immediately for any actions except those you command. It stops unwanted movement in yaw, pitch and roll while also correcting drift in any direction.

Heli-Max 230Si

US\$ 180.00

Heli-Max



ALTITUDE CONTROL MANAGEMENT

Auto Hover mode, maximum 10 metres altitude, press a button and the drone holds the altitude.



ACTUAL DIRECTION CONTROL

Unit goes in the same direction that pilot moves the stick, whether it's flying toward or away from the pilot.



RETURN TO PILOT

Brings the 230Si back to its pilot automatically. Push a button. And built-in sensor call the unit home.

FEATURES

- Beginner and expert flight modes.
- Fly indoors or outdoors.
- Flights times: up to 15 minutes.
- Fail-Safe: when radio signal is lost while flying the drone holds for one minute and starts a slowly descend.
- Two versions of the 230Si: HD digital onboard camera plus 2GB memory card or without it.
- 2.4GHZ SLT compatible transmitter.
- LEDs integrated into the body for low-light conditions.

DESCRIPTION

- Rotor Diameter: 14.4 cm.
- Diagonal Dimensions: 23.0 cm.
- Weight (with camera): 132 g.

Syma X5 Explorers

US\$ 80.00

SYMA



FEATURES

- Six-axis Gyro stabilization system makes the drone more stable.
- Wind-resistant characteristics, indoor or outdoor.
- Modular design structure, simple for assembly and maintenance.
- 360 degree Eversion and throwing flight function.
- Hand throttle mode can be changeable (Mode 1-2).

PACKAGE INCLUDES

- 1 x Syma X5 RC Quad.
- 1 x 2.4G Remote Controller.
- 1 x USB charging cable.
- 4 x Rotating blade.
- 4 x Protection frames.
- 2 x Landing skids.
- 1 x Screwdriver.
- 1 x 3.7V 500mAh Li-po battery.
- 1 x User Manual

DESCRIPTION

- Control Distance: about 30 m.
- Charging Time: About 100 min.
- Play Time: About 7 min.
- With 2.0MP HD camera for aerial photography.

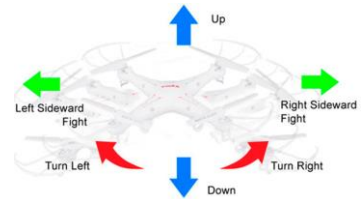



Vitality JJ-H30 EVO-Flyer

US\$ 60.00



DESCRIPTION

- Product Size: 18.8 cm x 18.8 cm.
- Height: 4.6 cm | Battery for Quadcopter: 3.7V 350MAH Li-po battery.
- Battery for Transmitter: 4 x 1.5V AA battery (not included).
- Charging time: about 60 min | Flight time: 6 min.
- Controlled distance: 30 m.

FEATURES

- High stability during hover and flight | Very responsive.
- One Key automatic tumbling | Three Modes Transmitter.
- Camera, Video & Photo Catch | Indoor and outdoor flying.

PACKAGE INCLUDES

- 1 x Vitality JJ-H30 Quad | 1 x Transmitter | 1 x 3.7V 350MAH Li-po.
- 1 x USB Charging Cable | 4 x Spare Propeller | 4 x Protective circle.



Dualsky Hornet 460

US\$ 260.00



FEATURES

- 90% factory assembled.
- Unit is fitted with white-red LED lighting.

DESCRIPTION

- Rotors: Four | Size - shaft to shaft: 46.0 cm.
- Height 11.0 cm | Weight: 780 g (without battery).
- Motors Dualsky XM2830CA-14, 830 RPM/V 55g 200W.
- Flight control unit: Dualsky FC430.
- Maximum weight: 1800 g | Battery Not included.

PACKAGE INCLUDES

- 1 X Hornet 460 Quad | **Note:** Li-po Battery, Charger, Radio, Receiver and Camera are not included.

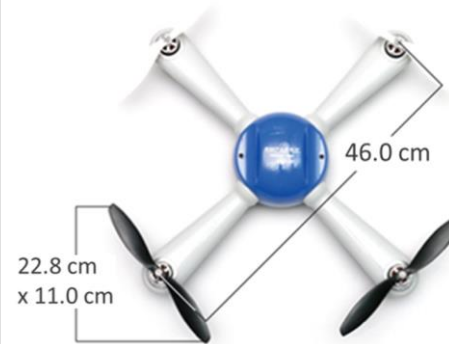

22.8 cm
x 11.0 cm



CAMERA
MOUNT

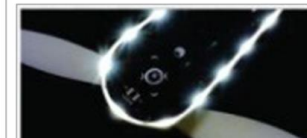

EQUIPPED WITH LED LIGHTS



JJRC F180

US\$ 80.00



FEATURES

- 360 Degree Rotating | 2.4G Transmitter.
- Easy Adjust Frequency | Four units of Searching Lights.
- Remote Control distance: 100 m | Built-in 6-Axis GYRO system.
- Easy Recharge | Shell protector prevents quad from damaged.

ESPECIFICATION

- Flight duration: 7 - 8 min.
- Control distance: less than 100 m.
- Recharging time: 60 min.
- Battery for quad: Li-po Battery 3.7V 250MAH.
- Colors: black and red, gold, black and blue.
- Material: plastic and metal.
- Mode 2 (Left hand throttle).

PACKAGE INCLUDES

- 1 x Quad Copter.
- 1 x 3.7V 500mAh Li-po Battery.
- 1 x Protection Frame.
- 1 x Transmitter.
- 1 x Detailed Operation Manual.
- 1 x USB Charger line.
- 5 x Foot nails.



Align M424

US\$ 110.00

ALIGN

FEATURES

- Unique mounts simplifies maintenance.
- Graphics printed on blades to shows orientation during flight.
- Helical gear design for quiet flights | LED lights to improve flight visibility.
- Supports iPhone or Android as controller using transmitter attachment (optional equipment).

DESCRIPTION

- Shaft to shaft rotor: 24.0 cm.
- Propeller width: 14.0 cm.
- Weight with battery: 95g.

PACKAGE INCLUDES

- 1 x M424 Quad | 1 x AT 100 Transmitter.
- 1 x 530mAh Li-Po Battery | 1 x CH240 Charger.
- 1 x USB Cable | 1 x Hex Wrenches | 1 x CD ROM.



RC EYE One Xtreme

(Announced)

U\$ 300.00

RCLogger



LEDS

FLIGHT CONTROL BOARD

CAM

GPS

CAMERA TRAY

LI-PO BATTERY

FEATURES

- Six-axis gyro stabilization technology | Three selectable flight modes.
- 2.4GHz, "OneLINK" and PPM Ready | The Quad is ready to fly.
- Automatic altitude hold function | 2.4 GHz transmitter interference free.
- Front white LED / two flashing lights on back part of the craft.

DESCRIPTION

- Diameter: 18.0 cm | Flight time: 5-7 min | Indoors and outdoors.
- Propeller \varnothing : 13.8 cm or 15.0 cm | Rechargeable: 7.4 V Li-po battery.
- Height: 8.0 cm (short) 11.5 cm (long legs) | Weight: 157 g - 161 g.
- Charger 500 mA per charging channel | 1.5 A | 5 V.

PACKAGE INCLUDES

- 1 x RC EYE One Xtreme Quad | 1 x 2.4 GHz Transmitter.
- 1 x Li-po Battery (800 mAh) | 1 x USB Li-po Battery Charger.
- 4 x Propeller | 2 x Spinner | 2 x Spinner Washer.
- 2 x AAA Battery for Transmitter | 1 x Sticker | 1 x Trigger Cable.
- 1 x PPM Cable (for optional PPM receiver) | Operating instructions.

ADD-ONS (MODULES):

PC Software: allows to display all add-on modules data.

GPS: shows speed, course, altitude, time-date, position, distance.

Power & RPM: shows Li-Po cell voltage, current drawn, motor rpm.

Environmental: four temperature sensors, humidity & atmospheric pressure sensor.

Orientation & G-Force: shows position, orientation and acceleration. Includes a gyro, a compass, accelerometer and magnetometer.

OPTIONAL LENS



FISH EYES

TELEPHOTO

WIDE ANGLE

3DR Iris

U\$ 750.00

3DR



FEATURES

- Wide-angled arms | GoPro-compatible camera mount (optional).
- Custom mission planning with GPS waypoint navigation (simple point-and-click programming).
- Custom FlySky RC transmitter | Multiple control options: RC, computer, phone and tablet.
- Failsafe programming options in lost control signal, GPS or low battery situation.
- Stabilized loitering | Return to launch | Circling mode | Firmware updatable.

DESCRIPTION

- Motor to motor dimension: 55.0 cm | Height: 10.0 cm | Weight (with battery): 1282 g.
- Payload capacity: 425 g | Flight time: 10 - 15 min (no gimbal) or 7 - 8 min (with gimbal).
- Battery: 3-cell 11.1 V 3500 mAh Li-Po (262 g) | Micro-USB ground station connector cable.
- GPS with integrated magnetometer.

PACKAGE INCLUDES

- 1 x Quad | 1 x 2.4 GHz Transmitter
- 1 x Li-po Battery (3500 mAh) | 1 x Battery Charger
- 4 x Propeller | Operating instructions.



Radio Telemetry Module 3DR
(915Mhz or 433MHz version)



Silverlit Space Galaxy

U\$ 100.00

silverlit



PRODUCT DESCRIPTION

- Space Galaxy is a gyro stabilized quad (indoors or outside).
- Four channel proportional radio for full directional control.
- Tough injection molded materials.
- Four rings to protect the propellers.
- Two pairs of red and green LED lights to assist orientation.
- Powerful lithium polymer battery makes possible to fly for up to ten minutes.
- Recharging process direct from the transmitter in less than half an hour.
- Pre-installed four channel proportional 2.4GHz radio control system.



PACKAGE INCLUDES

- 1 x Quadcopter ready-to-fly | 1 x Manual.
- 1 x 2.4GHz 4-Channel Radio Transmitter.
- 1 x Rechargeable Li-po Battery (incorporated in).

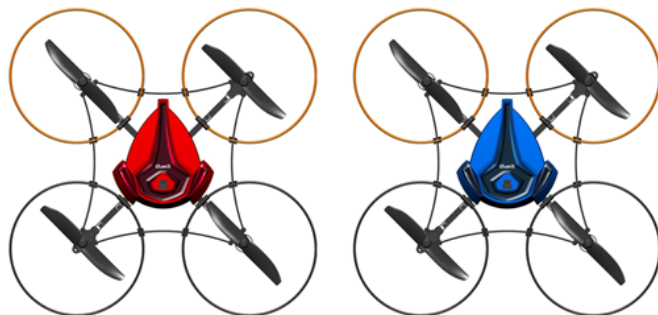

Quad with four channels digital proportional control.
Transmitter with trims possibilities to flying easier.
2.4 remote control technology (no signal overlap).
Built-in gyroscope delivers steady flight control.
Recharge through the transmitter.



Silverlit Space Comet

U\$ 80.00

silverlit



FEATURES

- Dimensions: 19 cm x 19 cm.
- Four-channel ready-to-fly 2.4GHz radio control quad.
- Suitable for operation indoors or outside.
- Lithium polymer battery for long flights.
- Fast recharging direct from the transmitter.
- Full proportional control plus a four axis flip facility.

DESCRIPTION

- Weight: 399 g | No assembly required.
- Remote control included 4 channels.
- Radio control frequency 34.945 MHz - 35.305 MHz.





Syma X4 Assault

US\$ 80.00



DESCRIPTION

- Product Size: 14.5 cm x 14.5 cm x 3.5cm.
- Channel: 4 CH | Frequency: 2.4GHz
- Control distance: 50 meters
- Battery: 3.7V 200mAh Li-Po.
- Charging time: 30 min.
- Flight time: 6 min.

FEATURES

- Flash lights | 360-degree 3D.
- Special functions: continuous rolling.

PACKAGE INCLUDES

- 1 x Syma X4 Quad (left hand throttle).
- 1 x 2.4 GHz transmitter.
- 1 x Li-Poly battery | 1 x USB charging cable | 4 x Spare blades.



The excellent frequency and bandwidth. Spread spectrum for better remote distance and anti-interference condition. Reaction speed 100 times faster than other RC transmitters.

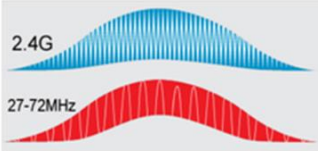

INDOOR
OUTDOOR



4
CHANNEL



2.4 G
(27-72 MHz)



360°
EVERSION



6 AXIS
STABILIZATION



TWO MODE
SELECTION



Li-Po
Battery



Syma X6

US\$ 100.00



DESCRIPTION







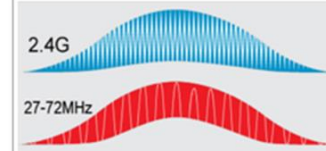





- Dimension: 57 cm x 57 cm x 10 cm.
- Novice and expert mode.
- Protective cover made of resistant material.
- LED flashing light for night flight.
- 2.4G Digital Transmitter with LCD display.
- Frequency: 2.4G (Spread Spectrum)
- Battery: 7.4V 850mAh Li-Po.
- Charging Time: 120 min.
- Flight time: 8 - 10 min.
- Control distance: 80 - 100 m.













PACKAGE INCLUDES













- 1 x Syma X6 Quad.
- 1 x 2.4G Transmitter with LCD display.
- 1 x 7.4V 850mAh battery.
- 1 x Li-Po charger.
- 4 x spare blades.



The excellent frequency and bandwidth. Spread spectrum for better remote distance and anti-interference condition. Reaction speed 100 times faster than other RC transmitters.

#	MODEL NAME MANUFACTURER												
		DJI PHANTOM 2 VISION	PARROT AR.DRONE GPS EDITION	PARROT BEBOP	PARROT ROLLING SPIDER	UDI U818A	UDI U816A	HUBSAN H107D	HUBSAN H109S X4 PRO	NINE EAGLE GALAXY VISITOR 2	NINE EAGLE GALAXY VISITOR 3	WALKERA QR X350 PRO	WALKERA QR X400
1	MANUFACTURER MODEL NAME	DJI PHANTOM 2 VISION	PARROT AR.DRONE GPS EDITION	PARROT BEBOP	PARROT ROLLING SPIDER	UDI U818A	UDI U816A	HUBSAN X4 H107D	HUBSAN H109S X4 PRO	NINE EAGLE GALAXY VISITOR 2	NINE EAGLE GALAXY VISITOR 3	WALKERA QR X350 PRO	WALKERA QR X400
2	DIMENSIONS LENGTH x WIDTH X HEIGHT (cm)	24.9 x 24.9 x 19.0	45.1 x 45.1 x 11.0	28.0 x 28.0 x 3.6	9.0 x 9.0 x 3.8	34 x 34 x 5.5	16.5 x 16.5 x 9.5	8.9 x 8.6 x 5.6	26.0 x 26.0 (motor to motor)	10.2 x 10.2 x 4.6	16.3 x 16.3 x 7.8	28.9 x 28.9 x 20.0	27.0 x 27.0 x 20.0
3	WEIGHT (g.)	1000	380 (w/o hull)	380 (w/o hull)	55 (w/o hull)	70.3	43.0	50.5	-	46.3	135	1000	786
4	MOTOR	920KV brushless, gearless motor	15 W, 10,350to 41,400 RPM, brushless, geared motor	brushless, gearless motor (specs not available)	brushless, gearless motor (specs not available)	brushless, geared motor	gearless motor	coreless, gearless motor	-	coreless, gearless motor	coreless, gearless motor	Brushless, gearless 15A (G/R)	Brushless, gearless
5	QUAD BATTERY	11.1V, 5200mAh Li-Po	11.1V, 1000 mAh Li-Po	1200mAh Li-Po	Li-Po (specs not available)	3.7V, 500mAh Li-Po	3.7V, 240mAh Li-Po	3.7V 380mAh Li-po	11.1V, 7000 mAh Li-po	3.7V, 300 mAh Li-po	3.7V, 300 mAh Li-po	11.1V, 5200mAh Li-po	11.1V, 2200mAh Li-po
6	MAX FLYING TIME (min)	25	12	12	8	9	10	7	25	8	15	25	25
7	CHARGING TIME (min)	90	90	120	90	120	60	30	-	30	30	60	60
8	AXIS GYROS	-	3-axis magnetometer + 3-axis gyro + 3-axis accelerometer	3-axis magnetometer + 3-axis gyro + 3-axis accelerometer	3-axis gyro + 3-axis accelerometer	3-axis gyro + 3-axis accelerometer	3-axis gyro + 3-axis accelerometer	3-axis gyro + 3-axis accelerometer adjustable	3-axis gyro + 3-axis accelerometer adjustable	3-axis magnetometer + 3-axis gyro + 3-axis accelerometer	3-axis magnetometer + 3-axis gyro + 3-axis accelerometer	3-axis gyro + 3-axis accelerometer	3-axis gyro + 3-axis accelerometer
9	GPS MODULE	Yes	Yes	Yes	No	No	No	No	Yes	No	No	Yes	Optional
10	RETURN HOME FUNCTION	Yes	Yes	Yes	No	No	No	No	Yes	Yes	Yes	Yes	Yes
11	FAIL SAFE MODULE	Yes	Yes	Yes	No	No	No	No	-	No	No	Yes	Yes
12	STABILIZATION SENSORS	No	Pressure + Ultrasound sensors	Pressure + Ultrasound sensors + vertical camera	Pressure + Ultrasound sensors + vertical camera	No	No	No	Barometer altitude hold	No	Build in Altitude sensor	No	No
13	CAMERA (Specs)	14 MP	-	14 MP fisheye-lens	Vertical Camera (Take snapshots)	Video Camera FPV	No	Video Camera FPV	Video Camera FPV	On board micro digital video and picture camera	On board micro digital video and picture camera	iLook or GoPro	On board micro digital video and picture camera
14	PIXELS RESOLUTION	1080p 30-60fps	720p 30fps	1080p 30-60fps	-	640 x 480 pixels	No	0.3M pixels 640 x 480	-	720p, 30fps	720p, 30fps	1080p 30-60fps	720p 30fps
15	VIDEO-PHOTO RECORDING	Yes	Yes	Yes	No	Yes	No	Yes	Yes	No	No	Yes	Yes
16	NAV DATA RECORDING	No	Yes	Yes	No	No	No	No	-	No	No	Yes	Optional
17	App AVAILABLE	Yes	Yes	Yes	Yes	No	No	No	-	No	No	Yes	No
18	WIFI	Yes	Yes	Yes	Yes	No	No	No	Yes	No	No	Yes	No
19	VIDEO DOWNLINK	Yes	Yes	Yes	No	No	No	Yes	Yes	No	No	Yes	No
20	REMOTE CONTROL	Wi-Fi Downlink for smartphones & tablets	Wi-Fi Downlink for smartphones & tablets	Wi-Fi Downlink for smartphones & tablets	Wi-Fi Downlink for smartphones & tablets	RC Transmitter	RC Transmitter	RC Transmitter (Live video distance - 100 m)	-	RC Transmitter	RC Transmitter	Wi-Fi Downlink for smartphones & tablets	RC Transmitter
21	CHANNELS FREQUENCY	2.4 GHz	2.4 GHz	MIMO 2.4 and 5GHz	Connection: Bluetooth Smart tech (Bluetooth Low Energy)	2.4GHz 4 Channel	2.4GHz 4 Channel	2.4GHz 4 channels (4.3 Inch LCD)	2.4GHz / 5.8GHz (video)	2.4GHz 4 Channel	2.4GHz 4 Channel	2.4GHz DEVO 10	2.4GHz DEVO 7
22	CONTROLLING DISTANCE (m)	300	50	30 (w/o extender) or 2000 (with Parrot Skycontroller)	20	30	30	50	300 - 2000	100 - 200	100 - 200	2000	100 - 200
23	CAMERA MOUNT	No	No	No	No	No	No	No	Yes	No	No	Yes	No
24	GIMBAL STABILIZATION	Yes	No	Stabilized video w/o gimbal	No	No	No	No	3D Camera	No	No	G-2D Brushless	No
25	PRICE (Average - US dollar)	1,000.00	460.00	Not announced yet	100.00	90.00	70.00	150.00	Not announced yet	130.00	160.00	650.00	380.00
26	BNF or RTF	RTF	RTF	RTF	RTF	RTF	RTF	RTF	-	RTF	RTF	RTF	RTF
27	OBSERVATION	Phantom FC 40, Phantom 2, Phantom 2 Vision, 2 Vision +	Elite Edition, Power Edition, GPS Edition	Announced for Q4-2014	Video/Photo recording: 8GB in MP4, and JPEGs format.	2GB Micro SD card	Foam made protective ring around the rotors	SD card for video recorder in transmitter (720 x 240)	Poor specifications available about this quad 😊	Headless Flying, Auto-Return & Brake function	Headless Flying, Auto-Return & Brake function	camera anti-vibration 2-axis stabilization	Telemetry module & GPS SENSOR (optional)

#	MODEL NAME MANUFACTURER												
0	MANUFACTURER MODEL NAME	WALKERA QR INFRA X	WALKERA LADYBIRD V2	WALKERA UFO MX400S	WALKERA QR W100S	WALKERA HM HOTEN X	BLADE 350 QX	VLYOYS V959	VLYOYS V262 (Cyclone)	VLYOYS V303 SEEKER	LOTUSRC T380	TRAXXAS QR1	TRAXXAS ALIAS
1	DIMENSIONS LENGTH x WIDTH X HEIGHT (cm)	10.8 x 10.8 x 6.2	8.5 x 8.5 x 3.0	27.0 x 27.0 x 19.0	14.4 x 14.4 x 4.4	26.5 x 26.5 x 9.5	46.5 x 46.5 x 19.0	19.0 x 19.0 x 8.0	55.0 x 55.0 x 5.0	30.5 x 30.5 x 18.5	41.0 x 41.0 x 14.0	12.0 x 12.0 x 2.8	23.5 x 23.5 x 4.3
2	WEIGHT (g.)	73	35	786	76	332.3	680	82	80	770	610	33	100
3	MOTOR	coreless, gearless motor	brushless, gearless motor	brushless, gearless motor	gear driven motor	brushless, gearless motor	brushless, 1100kV	brush, gear driven motor	brush, gear driven motor	brushless, 950kv	brushless, gearless motor	gearless motor	brushed, coreless gear driven motor
4	QUAD BATTERY	3.7V, 600mAh Li-Po	3.7V, 240mAh Li-Po	11.1V 2200mAh Li-Po	3.7V, 600mAh Li-Po	7.4V, 1000mAh Li-Po	11.1V, 2200mAh Li-Po	3.7V, 500mAh Li-Po	7.4V, 850mAh Li-Po	11.1V, 2700mAh	11.1V, 2200mAh Li-Po	3.7V, 240mAh Li-Po	3.7V, 650mAh Li-Po
5	MAX FLYING TIME (min)	7	8	10	8	10	15	10	10	15	25	8	15
6	CHARGING TIME (min)	60	60	90	60	90	90	90	90	90	90	60	90
7	AXIS GYROS	3-axis gyro + 3-axis accelerometer	3-axis gyro + 3-axis accelerometer	3-axis gyro + 3-axis accelerometer	3-axis gyro + 3-axis accelerometer	3-axis gyro + 3-axis accelerometer	3-axis gyro + 3-axis accelerometer	3-axis gyro + 3-axis accelerometer	3-axis gyro + 3-axis accelerometer	3-axis gyro + 3-axis accelerometer	3-axis gyro + 3-axis accelerometer	3-axis gyro + 3-axis accelerometer	3-axis gyro + 3-axis accelerometer
8	GPS MODULE	No	No	optional	No	No	Yes	No	No	Yes	No	No	No
9	RETURN HOME FUNCTION	No	No	No	No	No	Yes	No	No	Yes	No	No	No
10	FAIL SAFE MODULE	No	No	No	No	No	Yes	No	No	Yes	Yes	No	No
11	STABILIZATION SENSORS	Infrared, ultrasonic	No	No	No	No	Yes	No	No	No	No	No	No
12	CAMERA (Specs)	No	On-board 5.8G FPV camera	micro digital video and picture camera (optional)	30W pixel HD camera	On-board 5.8G FPV camera (200 mega pixel)	GoPro compatible	On-board FPV camera	Optional: On-board FPV camera (0.3 MP)	GoPro compatible	No	No	optional
13	PIXELS RESOLUTION	No	0.3M pixels 1280 x 720	720p 30fps	720 x 480 SVGA	720p	Full HD 1080p	720 x 480, 60fps	640 x 480 SVGA	Full HD 1080p	No	No	720p 30fps
14	VIDEO-PHOTO RECORDING	No	optional	optional	Yes	Yes	Yes	Yes	optional	Yes	No	No	optional
15	NAV DATA RECORDING	No	No	optional	No	No	No	No	No	No	No	No	No
16	App AVAILABLE	No	No	No	Yes	No	No	No	No	No	No	No	No
17	WIFI	No	No	No	Yes	No	GoPro wifi	No	No	GoPro wifi	No	No	No
18	VIDEO DOWNLINK	No	No	No	Yes	No	Yes	No	No	Yes	No	No	No
19	REMOTE CONTROL	RC Transmitter (DEVO 4)	RC Transmitter (DEVO 4)	RC Transmitter (compatible with DEVO 7 to 10)	RC Transmitter & Wi-Fi Downlink for phone & tablet	RC Transmitter (DEVO 7)	RC Transmitter (DX5E)	RC Transmitter (LCD Display Screen) (LCD)	RC Transmitter (DEVO 4)	RC Transmitter (LCD radio)	RC Transmitter (DEVO 7)	RC Traxxas Transmitter	RC Traxxas Transmitter
20	CHANNELS FREQUENCY	2.4GHz 4 Channel	2.4GHz 4 Channel	2.4GHz 4 Channel	2.4GHz 4 Channel	2.4GHz 4 Channel	2.4GHz 4 Channel	2.4GHz 4 Channel	2.4GHz 4 Channel	2.4GHz 4 Channel	2.4GHz 4 Channel	2.4GHz 4 Channel	2.4GHz 6 channel
21	CONTROLLING DISTANCE (m)	100	30	50	80	100	100	40	150	500	100	30	50
22	CAMERA MOUNT	No	optional	No	No	No	Yes	No	No	Yes	optional	No	No
23	GIMBAL STABILIZATION	No	No	No	No	No	2-Axis Brushless	No	No	optional	No	No	No
24	PRICE (Average - US dollar)	160.00	170.00	350.00	110.00	230.00	470.00	80.00	90.00	420.00	220.00	60.00	160.00
25	BNF or RTF	RTF	RTF	w/o Transmitter	RTF	RTF	Bind-N-Fly Version (Model BLH7880A)	RTF	RTF	RTF	RTF	RTF	RTF
26	OBSERVATION	Infrared Obstacles avoidance Ultrasonic Altitude Hold	3D maneuvers: pirouettes, flips, rolls	GPS functions Bi-direction transmitting for telemetry	Real-time first person view on the iPhone or iPad.	RX firmware-update Online from Walkera website	Ready-To-Fly Version (Model BLH7800A)	Micro SD Card 2G Card Transport to Computer	Camera not included	Low voltage protection, Self Landing, headless mode	Auto level, MEMS sensor 6DOF stabilization	Hight durability	Crash-proof, full information available about this quad ©

#	MODEL NAME MANUFACTURER												
1	MANUFACTURER MODEL NAME	HELI-MAX 230i	SYMA X5 EXPLORER	VITALITY JJ-H30 EVO FLYER	DUALSKY HORNET 460	JJRC F180	ALIGN 424	RC EYE ONE XTREME (series)	3DR IRIS	SILVERLIT SPACE GALAXY	SILVERLIT SPACE COMET	SYMA X4 ASSAULT	SYMA X6
2	DIMENSIONS LENGTH x WIDTH X HEIGHT (cm)	30.6 x 30.6 x 7.5	31.5 x 31.5 x 8.0	18.8 x 18.8 x 4.6	46.0 x 46.0 x 11	13.0 x 13.0 x 3.0	24.0 x 24.0 x 5.2	Quad Ø 18.0 Propeller Ø 13.8	55.0 x 55.0 x 10.0	22.9 x 22.9	19.0 x 19.0	14.5 x 14.5 x 3.5	57.0 x 57.0 x 10.0
3	WEIGHT (g.)	132	160	43	780	56	95	157	1282	85	55	42	320
4	MOTOR	gear driven motor	brush, gear drivem motor	gearless motor	brushless, 830 RPM, 200W	brush, gearless driven motor	helical gear, gearless driven motor	brushless, gearless driven motor	brushless, 850 kV, gearless driven motor	gearless driven motor	gearless driven motor	gear driven motor	gear driven motor
5	QUAD BATTERY	3.7V, 1200mAh Li-Po	3.7V, 500mAh LiP-Po	3.7V, 350mAh Li-Po	11.1V, 1700-4600mAh Li-Po	3.7V, 500mAh Li-Po	3.7V, 530mAh Li-Po	7.4 V, 800-1150 mAh Li-Po	11.1 V, 3500 mAh Li-Po	Built-in Li-Po (not removable)	Built-in Li-Po (not removable)	3.7V, 200mAh Li-Po	7.4V, 850mAh Li-Po
6	MAX FLYING TIME (min)	15	7	6	8	8	8	10	15	10	6	6	10
7	CHARGING TIME (min)	90	90	60	90	60	60	60	90	30	30	30	120
8	AXIS GYROS	3-axis gyro + 3-axis accelerometer	3-axis gyro + 3-axis accelerometer	3-axis gyro + 3-axis accelerometer	3-axis gyro + 3-axis accelerometer	3-axis gyro + 3-axis accelerometer	3-axis gyro + 3-axis accelerometer	3-axis gyro + 3-axis accelerometer	3-axis gyro + 3-axis accelerometer	3-axis gyro + 3-axis accelerometer	3-axis gyro + 3-axis accelerometer	3-axis gyro + 3-axis accelerometer	3-axis gyro + 3-axis accelerometer
9	GPS MODULE	No	No	No	No	No	No	Yes	Yes	No	No	No	No
10	RETURN HOME FUNCTION	Yes	No	No	No	No	No	No	Yes	No	No	No	No
11	FAIL SAFE MODULE	Yes	No	No	No	No	No	No	Yes	No	No	No	No
12	STABILIZATION SENSORS	No	No	No	No	No	No	Automatic altitude hold function	Yes	No	No	No	No
13	CAMERA (Specs)	On-board FPV camera	On-board FPV camera	Optional: On-board FPV camera (0.3 MP)	Optional Available	No	No	RC Logger HD2	GoPro ready	No	No	No	No
14	PIXELS RESOLUTION	720p, 30 fps	2.0 MP, HD Camera, 720p	640 x 480 SVGA	-	No	No	5.0 MP 1280 x 720	Full HD (1980 x1280)	No	No	No	No
15	VIDEO-PHOTO RECORDING	Yes	Yes	Yes	Optional Available	No	No	Yes	Yes	No	No	No	No
16	NAV DATA RECORDING	No	No	No	No	No	No	Yes	Yes	No	No	No	No
17	App AVAILABLE	No	No	No	No	No	Yes	Optional	Yes	No	No	No	No
18	WIFI	No	No	No	No	No	optional equipment	Optional	Yes	No	No	No	No
19	VIDEO DOWNLINK	No	No	No	No	No	No	Optional	Yes	No	No	No	No
20	REMOTE CONTROL	RC Transmitter (DEVO 4)	RC Transmitter (anti-interference tech)	RC Transmitter (VITALITY)	No	RC Transmitter (JJRC)	RC Transmitter (AT100) + Wi-Fi link for phone & tablet	RC Transmitter (RC Logger) or Optional OneLINK adapter	RC transmitter Link adapter 3DR for phone & tablet	RC transmitter	RC transmitter	RC transmitter	RC transmitter
21	CHANNELS FREQUENCY	2.4GHz SLT	2.4GHz	2.4GHz	No	2.4GHz	AFHDS 2.4ghz 3 Channel	2.4GHz (FHSS+PPM optional)	Radios available (915mHz or 433mHz)	2.4GHz 4 CH	2.4GHz 4 CH	2.4GHz 4 CH	2.4GHz 4 CH
22	CONTROLLING DISTANCE (m)	50	30	30	-	100	50	100	100	40	40	50	80
23	CAMERA MOUNT	No	No	No	Optional Available	No	No	No	Yes	No	No	No	No
24	GIMBAL STABILIZATION	No	No	No	Optional Available	No	No	No	Yes	No	No	No	No
25	PRICE (Average - US dollar)	180.00	80.00	60.00	260.00	80.00	110.00	300.00	750.00	100.00	80.00	80.00	100.00
26	BNF or RTF	RTF	RTF	RTF	Bind-N-Fly Version	RTF	RTF	RTF	Bind-N-Fly (w/o transmitter)	RTF	RTF	RTF	RTF
27	OBSERVATION	Stability, easier visibility, able to handle outdoor flying	360 degree Eversion and throwing flight function	Camera is not included	Without transmitter, receiver and LiPo charger	Protection rotor frame	IOS Android by transmitter attachment	ALSO: Transmitters models Futaba, JR, Spektrum, etc.	Sophisticated programmable quad, brushless gimbal	Poor specifications available about this quad 😞	Poor specifications available about this quad 😞	indoor/outdoor	Large quad

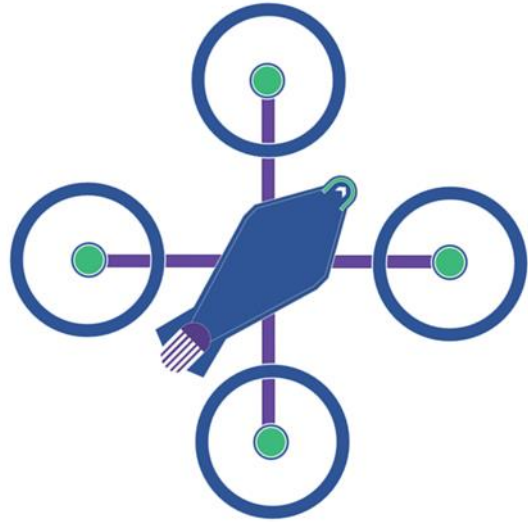

Quads For Fun

quadsforfun@outlook.com

